

FLEX Assemblies for Space Applications

Advantages of Flex Cable Assemblies in Space:

- reduced size and weight (up to 60% less weight and space)
- ability to fold and form
- reduced integration time
- reducing failure rates during wiring
- repeatability
- Higher density designs due to smaller pitch sizes or multiple layers (up to 34 layers)
- no more crimping or soldering
- enabling 3D designs
- small board to board or board to panel connections or long designs up to 33m possible
- Minimize solder joints
- pe-installed connectors

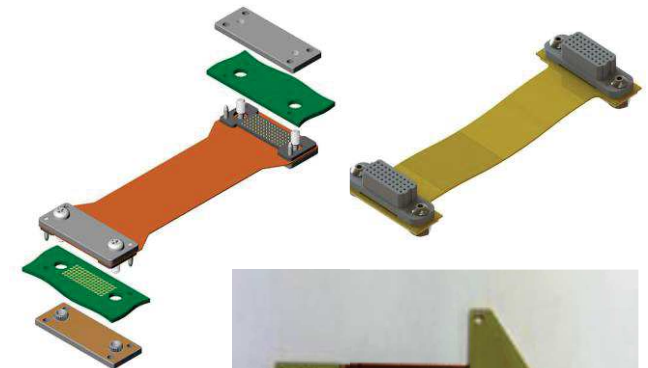
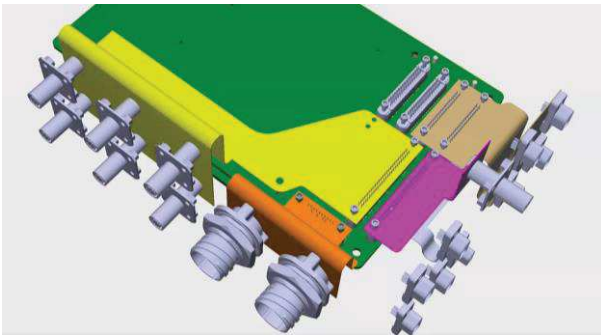
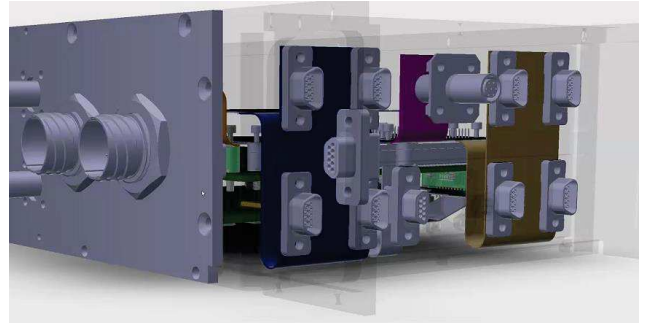
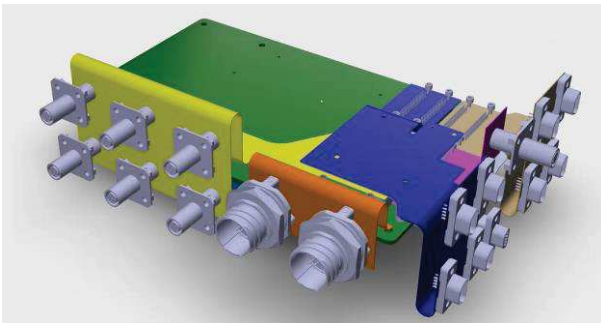
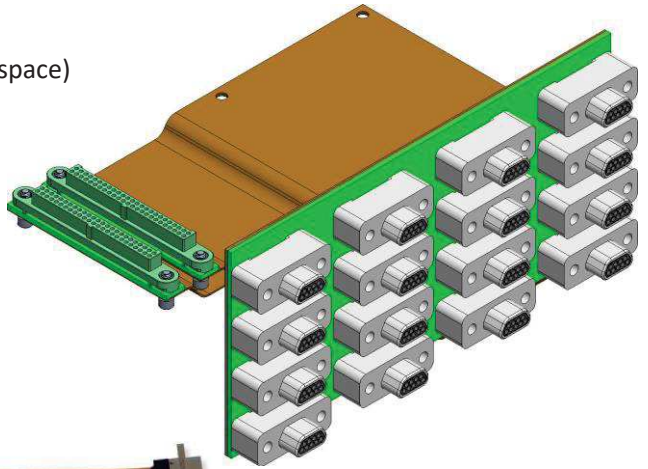

Extended Length Flex
Up to 33meter for Solar panels

